

R290 FULL-INVERTER SWIMMING POOL HEAT PUMP



CONTENTS

0 1 Installation & Operation

0 2 Function and Logic

0 3 Curcuit Diagram



1

Installation & Operation

Basic Information

Model	PW010-KZXYC-E PW020-KZXYC-E PW030-KZXYC-E	PW040-KZXYC-E PW050-KZXYC-E PW060-KZXYC-E	PW070-KZXYC-E PW080-KZXYC-E
R290			
Swimming Pool			
Quiet Pro(Plastic casing)			
Compressor HIGHLY			
Power Supply	230V/1 Ph/50Hz/60Hz		
Compressor brand	HIGHLY		
Body Size(W*D*H)/mm	1036*410*605	1130*480*816	1235*490*980
Operation Water Temp(°C) Heating	9 ~40		
Operation Water Temp(°C) Cooling	9 ~35		
Operation Water Temp(°C) Cooling	-20~43		

Model	PW010-KZXYC-E	PW020-KZXYC-E	PW030-KZXYC-E	PW040-KZXYC-E	PW050-KZXYC-E	PW060-KZXYC-E	PW070-KZXYC-E	PW080-KZXYC-E
Operating air temperature (°C)	-20 ~43							
Performance Condition: Air 27°C, Water 26°C, Humidity 80%								
Heating capacity (kW)	6.0~1.6	9.0~2.2	12.0~3.0	16.0~3.5	20.0~4.0	23.5~5.3	28~6.8	33.1~8.0
Heating Capacity(Btu)	20470~5460	30700~6820	40940~10240	54590~11940	68240~13650	80180~18080	95540~23200	112937~27296
Consumed power (kW)	1.07~0.13	1.39~0.16	2.07~0.21	2.66~0.25	3.33~0.28	4.28~0.44	4.42~0.49	5.33~0.58
COP	5.6~12.0	6.5~13.5	5.8~14.2	6.0~14.2	6.0~14.2	5.5~12.0	6.3~14.0	6.2~13.8
COP at 50% capacity	9.0	9.8	10.5	10.5	10.2	9.0	10.2	9.7
Performance Condition: Air 15°C, Water 26°C, Humidity 70%								
Heating capacity (kW)	4.6~1.3	7.0~1.7	9.0~2.2	11.8~2.7	15~3.0	17.8~3.8	23~5.5	25.2~7.5
Heating Capacity(Btu)	15700~4435	23880~5800	30700~7500	40260~9210	51180~10230	60730~12960	78476~18766	85982~25590
Consumed power (kW)	1.17~0.20	1.51~0.24	2.05~0.29	2.62~0.37	3.33~0.44	4.32~0.61	4.89~0.81	5.36~1.15
COP	3.9~6.2	4.6~7.0	4.4~7.5	4.5~7.3	4.5~6.8	4.1~6.2	4.7~6.8	4.7~6.5
COP at 50% capacity	5.5	5.8	5.6	6.5	6.1	5.6	6.3	6.2
Performance Condition: Air 35°C, Water 28°C, Humidity 80%								
Cooling capacity (kW)	4.0	6.0	8.0	10.0	11.3	13.0	14.9	17.5
Consumed power (kW)	1.05	1.58	2.35	2.63	2.97	3.47	3.92	4.06
EER	3.8	3.8	3.4	3.8	3.8	3.8	3.80	4.3
Heat exchanger	Spiral titanium tube in PVC							
Casing	ABS plastic casing black color							
Power supply	230V/1 Ph/50Hz/60Hz							
Max. power input(kW)	1.5	2.3	2.9	3.5	4.4	4.7	4.8	5.4
Max. current (A)	7.2	11.1	14.0	16.0	20.2	21.5	21.8	24.5
Advised water flux (m³/h)	2.6	3.9	5.2	6.9	8.6	10.3	12.04	13.76
Water Pressure Drop (max) kPa	2	5	9	9	14	19	11	20
Four-way valve	Sanhua							
Expansion valve	Sanhua							
Frequency drive board	CHICO							

Heat Pump Working Principle



Air source heat pump absorbs free energy from the air, and then transports the energy to cold water through the compressor doing work to heat large amounts of energy efficient hot water, thus realising the needs of central heating and domestic hot water.

A complete refrigeration cycle system consists of four major parts: Compressor, Evaporator, Condenser and Throttle device.

***Evaporator:** low temperature, low pressure refrigerant go through evaporator, vaporizes into low-temperature and low-pressure steam;

***Compressor:** compresses the refrigerant steam into high-temp high-pressure gas, which is discharged into the condenser.

***Condenser:** refrigerant release heat energy to heat exchanger, and it returns from gas status to liquid status. The heat energy is absorbed by water, then the hot water is sent to indoor user's end through the water pressure.

***EEV:** at last the refrigerant go through the electronic expansion valve, where its pressure is reduced, and then continues to the evaporator.

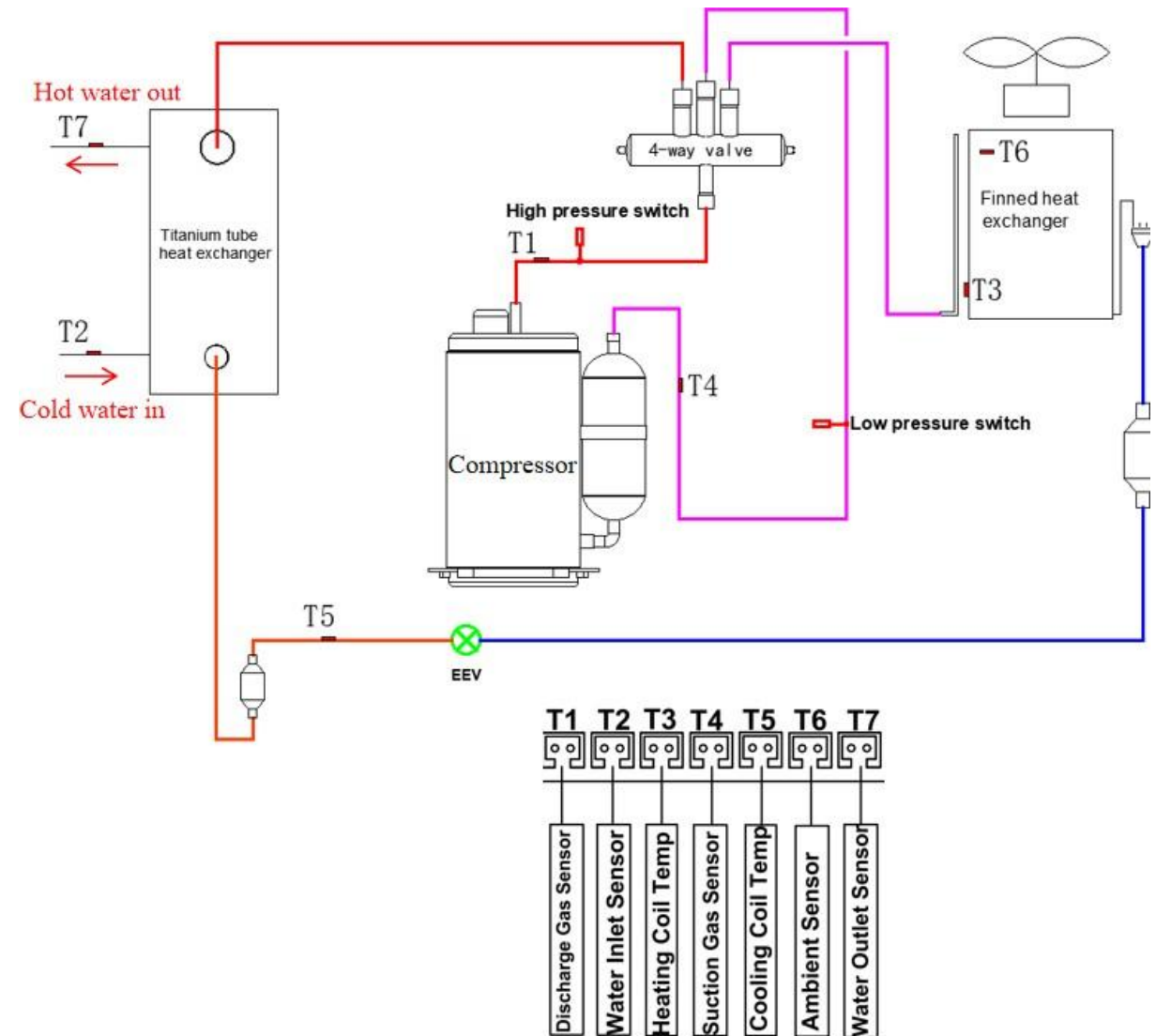

Exploded views

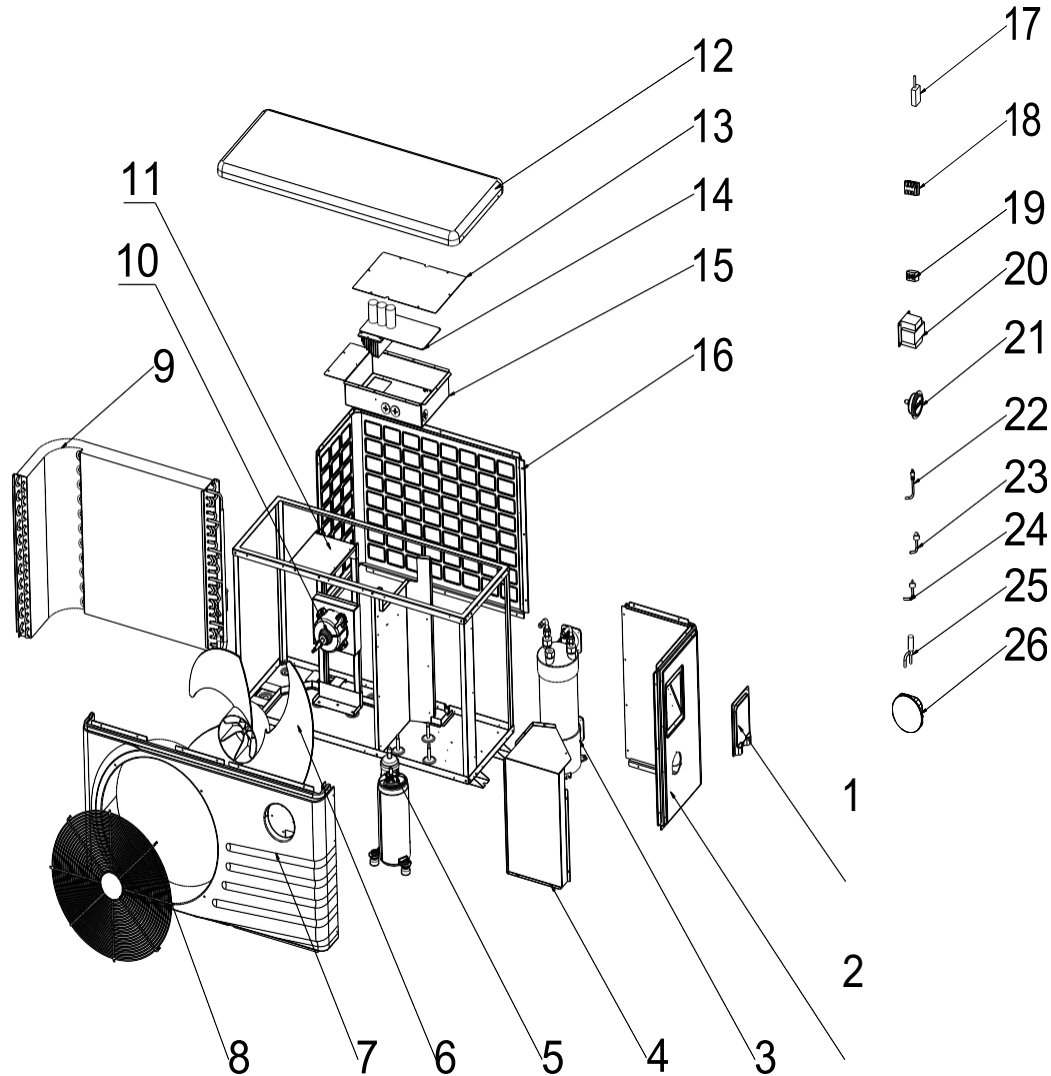

NO	Spare parts	NO	Spare parts
1	terminal block cover	16	behind panel
2	right side panel	17	R290 refrigerant leakage sensor
3	titanium foam	18	terminal block
4	noise suppressor cover	19	terminal block
5	compressor	20	electric reactor
6	fan blade	21	pressure gauge
7	front panel	22	needle valve
8	fan protection net	23	high pressure switch
9	finned heat-exchanger	24	low pressure switch
10	motor	25	electronic expansion valve
11	motor bracket	26	wired controller
12	top cover	27	needle valve
13	electric box cover		
14	driver board		
	electric box		

Application

The heat pump must be protected from back-siphoning of water. If there is any chance of back-siphoning, **provide a check valve between the swimming pool and the heat pump outlet.** The pool system components are Heat pump, Check Valve, Disinfection system, Filter and Water Pump.

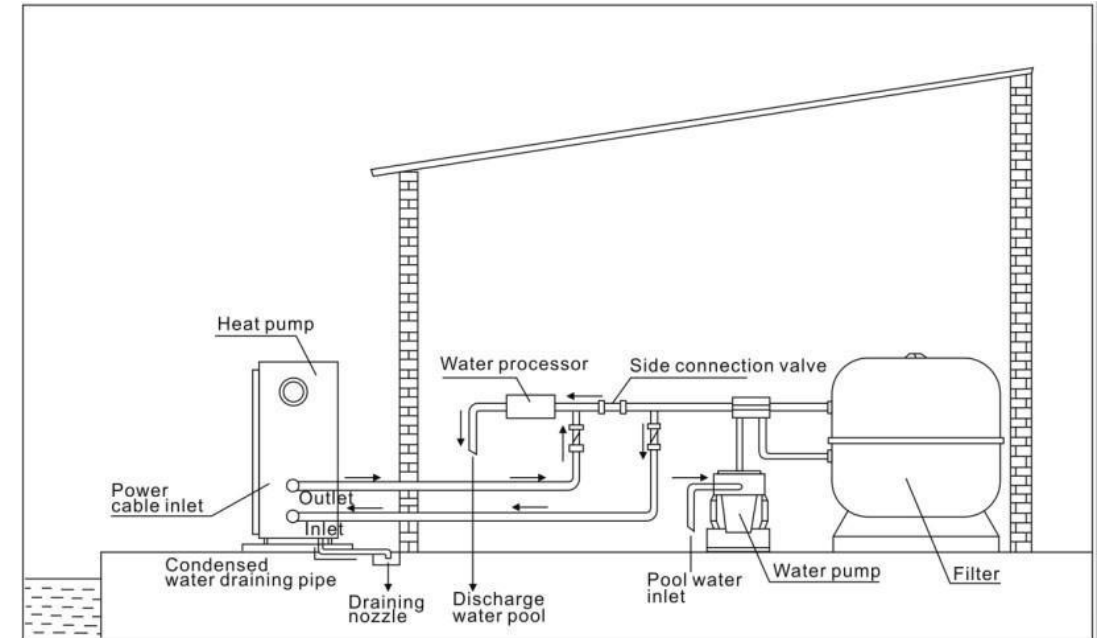
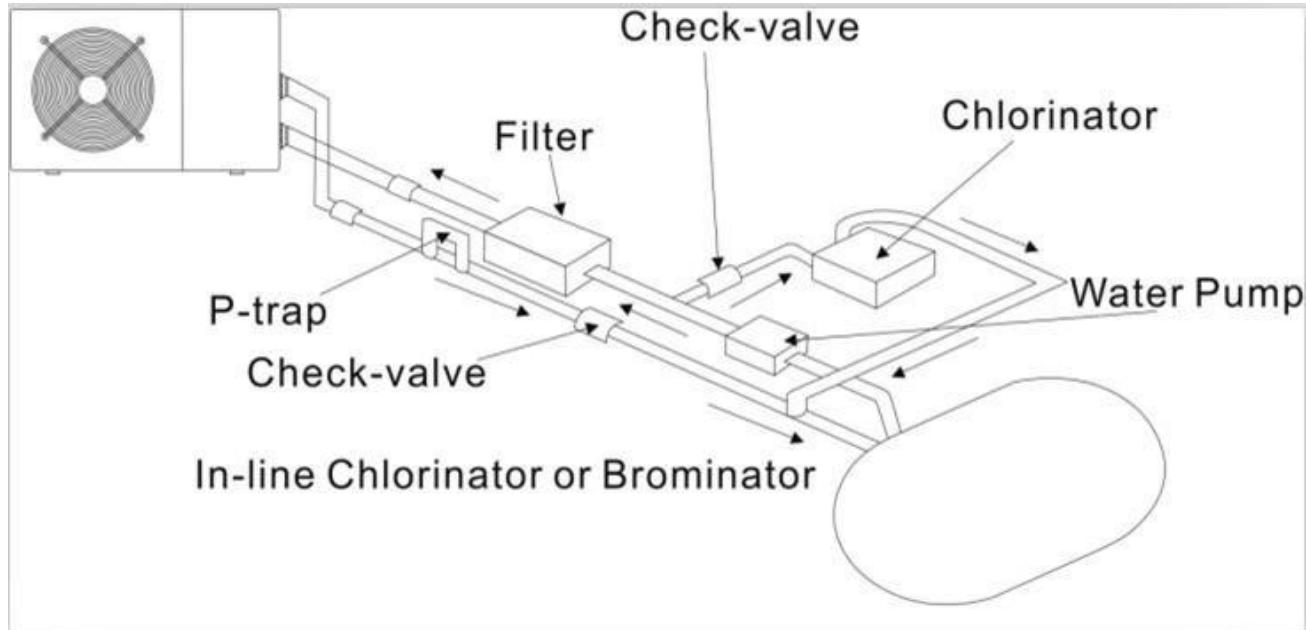

Installation



1. The heat pump installation area must have good ventilation and the air inlet/outlet must not be hindered.
2. The installation area must have good drainage and be built on a solid foundation.
3. Do not install the unit in areas accumulated with pollution like aggressive gas (chlorine or acidic), dust, sand and leaves etc.
4. For easier and better maintenance and troubleshooting, **no obstacles around the unit and the distance plz refer to the installation diagram below.**
5. The heat pump must be equipped with shock-absorbing bushings to prevent vibration and/or imbalance;
6. The controller should avoid direct sunlight and high temperatures, and be installed at a distance with good communication with the heat pump.
7. The pipeline must be installed with appropriate support to prevent possible damage due to vibration. The pressure of tap water should be maintained above 200kPa. Otherwise, a booster pump should be installed;
8. **The acceptable working voltage range should be within 10% ;**
9. For safety reasons, **the heat pump unit must be grounded.**

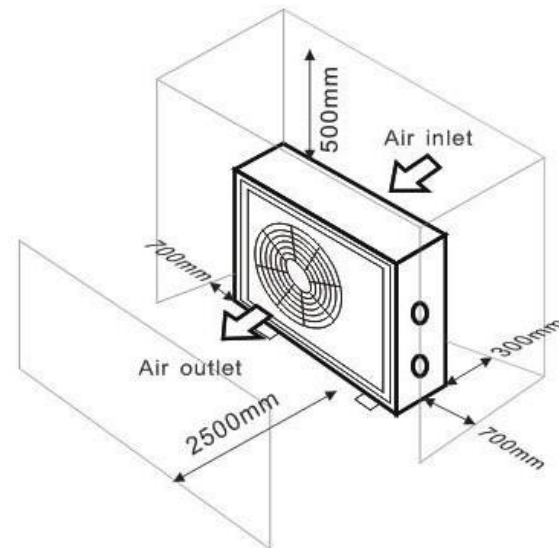

⚠ WARNING

- Before starting the installation of the heat pump, ensure that all high-voltage circuits are disconnected.
- When repairing a heat pump, mark all wires before disconnecting them. Wiring errors can lead to improper and dangerous operation.

• Electrical Wiring

1. If the supply voltage is too low or too high, it can cause damage and/or result in unstable operation of the heat pump unit, due to high inrush currents on start up.
2. The minimum starting voltage should be above 90% of rated voltage. The acceptable operating voltage range should be within $\pm 10\%$ of the rated voltage.
3. Ensure the cable specifications meet the correct requirements for the specific installation. The distance between the installation site and mains power supply will affect the cable thickness. Follow the local electrical standards to select the cables, circuit breakers and isolation breakers.
4. The compressor, electric heater and water pump all have AC-contactor and thermo relay protection.
5. Please ensure that all power supplies, electrical mainboard, compressors, motors, etc. are grounded.



















Single-phase power input

Wired Controller Operation

- This hot water is equipped with a wired controller from factory, users can set different water temp, timer setting, parameter query and so on.
- In the main interface, press  button for around 3 second to turn on or turn off the heat pump.



Icon meaning

Icon	Meaning	Icon	Meaning
	Heating mode		Cooling mode
	Fault		Defrosting mode
	Anti-freeze protection		Powerful Mode
	Standard Mode		Silent Mode
	Compressor		Fan
	Water Pump		Electric heater
	WIFI		Photovoltaic signal (EVU)
	Grid signal (SG)		Lock screen
	Clock		

Wired Controller Operation

- **Mode switching:** When the machine is turned on, long press "☰" to switch modes;
- **Temperature Setting:** When the machine is turned on, in the main interface, press "▲" or "▼" to set the temperature in the current mode;
- **Forced Defrosting:** Press and hold the "☰" and "⏻" keys at the same time to enter the forced defrost mode; When entering defrost mode, ❄️ is displayed.
- **Manual Electric Heating:** Long press "⏻" button for 3s to turn on/off electric heating manually.
- **Parameter Factory Setting Recovery:** In the off state, press and hold the "☰" key + "⏻" key + "▲" key + "▼" key for 3 seconds to restore the factory settings. The buzzer will sound twice in succession and all parameter values will return to the default values. **Temp °C switch to °F:** In the main interface, press and hold the button " " and " " button for 3S, it will switch the temperature unit.
- **Unlock Setting:** Press the "▲" + "▼" keys simultaneously for 3 seconds to enter the lock screen state, and press them simultaneously for 3 seconds again to exit the state;



Wired Controller Operation



- **Operation Parameter Query:** In the power on/off state, directly press the key on the main interface to enter the parameter query state. At this time, press , to query the parameters , as follows ;

Code	Name	Scope	Display value
A01	Inlet water temperature	- 30~99°C	Measured value
A02	Outlet water temperature	- 30~99°C	Measured value
A03	Ambient temperature	- 30~99°C	Measured value
A04	Exhaust gas temperature	0~125°C	Measured value
A05	Return gastemperature	- 30~99°C	Measured value
A06	External coil temperature	- 30~99°C	Measured value
A07	Inner coil temperature	- 30~99°C	Measured value
A08	Main expansion valve opening	0 ~ 480	
A09	Enthalpy increase expansion valve opening	0 ~ 480	
A10	Compressor current		
A11	Heat sink temperature		
A12	DC bus voltage value		
A13	Actual speed of press		
A14	DC fan 1 speed		When there is a single fan, it is displayed here. When there are two fans, it is the speed of fan 1
A15	DC fan 2 speed		When there is a single fan, it is displayed as 0. When there are two fans, it is the speed of fan 2
A16	Refrigerant gas concentration	0 ~ 100%	
A17	Low pressure value		
A18	Low pressure conversion temperature		

Wired Controller Operation



- **Parameter query and setting : (can be set on or off, password: 0814)**
- In the power on/off state, you can simultaneously press and hold the + keys for 3 seconds to enter the password input state. At this time, the tens digit "0" of the hour in the clock area flashes. At this time , short press the key to shift the position. The ones digit of the hour digit flashes. Combine and to input "8", and then press the key again . The tens digit of the minute digit flashes and input "1". Press the key again . The ones digit of the minute digit flashes and input "4". After the password is entered correctly, press the key again to confirm the password and enter the engineering parameter query interface (if the password is incorrect, it will return to the main interface);

Code	Parameter	Scope	Default value
P1	Temperature difference	1~18°C	1°C
P2	Cooling set temperature	8°C~35°C	27°C
P3	Heating set temperature	5°C~40°C	27°C
P4	Inlet water temperature compensation	-5°C~15°C	0°C
P5	Defrost cycle	20~90MIN	45MIN
P6	Defrost entry temperature	-9°C~-1°C	-3°C
P7	Defrost time	5~20MIN	8MIN
P8	Defrost exit temperature	1°C~40°C	20°C
P9	Defrost environment and coil temperature difference	0°C~15°C	9 °C
P10	Ambient temperature for defrosting	0°C~20°C	17°C
P27	Smart grid function	0:Disable1:Enable	0
P29	R290 refrigerant leakage sensor function	0:Disable1:Enable	1

Wired Controller Operation

- **Forced Exit Preheating**
- When the system power down time meets the conditions, the system enters the preheating state. At this time, the compressor icon '🔌' flashes to indicate that it has entered the preheating state. During the system preheating process, you can use the wired controller to press and hold the ⏻ and 🔄 keys simultaneously to force the system to exit this preheating.
- **WARNING:** Please note that after the heat pump is powered off for more than 4 hours, if the ambient temperature is too low and the compressor is not preheated, starting the compressor directly may cause the compressor to get stuck, damage the compressor or mainboard and other poor situations. Please pay attention to the preheating function.





2

Function and Logic

SG Ready Function



When the smart grid function (parameter P27) is enabled, the heat pump starts to run the smart grid function.

SMART GRID				
Mode	EVU	SG	Running status	Description
Working Mode 1	ON	OFF	Force shutdown	Heat pump forced to shut down compressor and fan(Low power mode, icon flashing)
Working Mode 2	OFF	OFF	Normal operation	Heat pump working properly
Working Mode 3	OFF	ON	Enhanced Mode	Heat pump running in powerfulmode
Working Mode 4	ON	ON	Forced to open	Heat pump running in powerfulmode

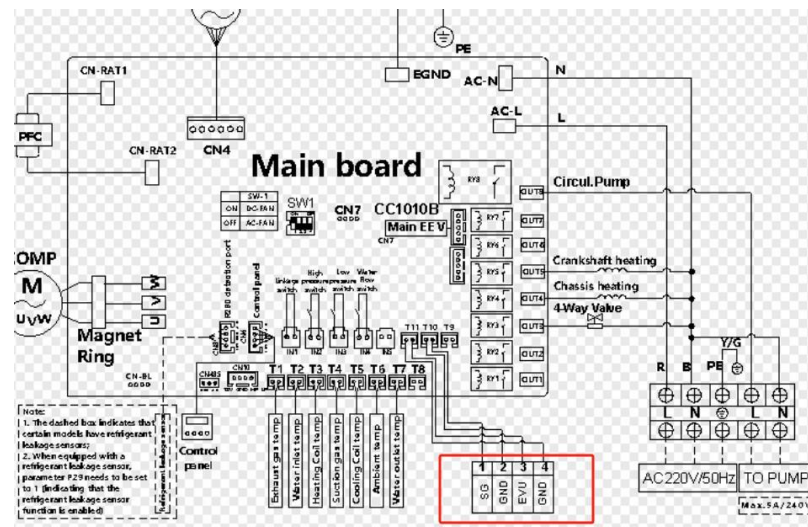

WIFI network configuration steps

1) Step 1:

Solution 1: When powering on, the interface of the wire controller will flash "" to enter the intelligent network connection. At this time, the network can be carried out. If there has been no pairing, the network will be exited and the intelligent network connection mode needs to be entered manually:

Press and hold the "⌘" and "⌘" keys for 5 seconds to enter the pairing state. The "📶" icon in the upper left corner flashes quickly. After successful pairing, the icon stays on. If pairing is unsuccessful or has not been paired, the icon will not be displayed after 3 minutes, and the network configuration state will be exited. The "📶" icon stops flashing, and the WIFI module will no longer be paired. To re-pair, press and hold the "⌘" and "⌘" keys for 5 seconds;

Solution 2: Press and hold the "⏻" and "⌘" keys for 3 seconds to enter the "Compatibility Mode" network configuration. The "📶" icon flashes slowly when entering.

2) Step 2: Turn on the Bluetooth and WIFI functions of your phone and connect to the WIFI hotspot. The WIFI hotspot must be able to connect to the Internet normally, as shown in the figure: Connect to the WIFI hotspot "pwwm";

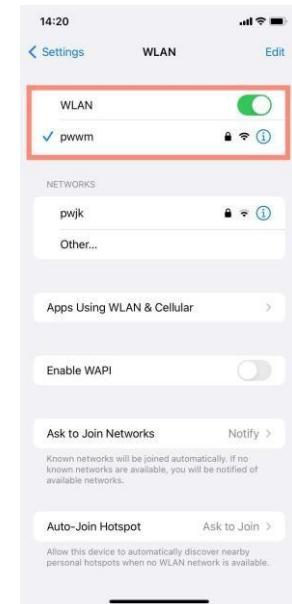
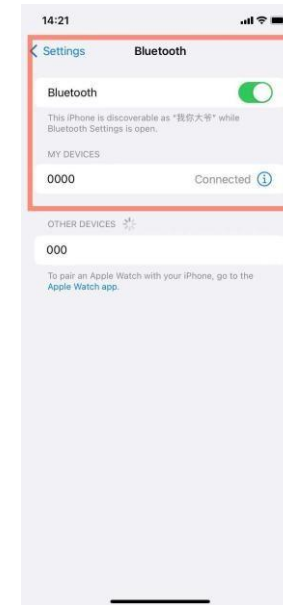

WiFi network configuration steps



3)Step 3:

Add device solution 1:

Open the "Smart Life" APP, log in to the main interface, click "Add Device" and select " Add " → enter WiFi information → Complete;

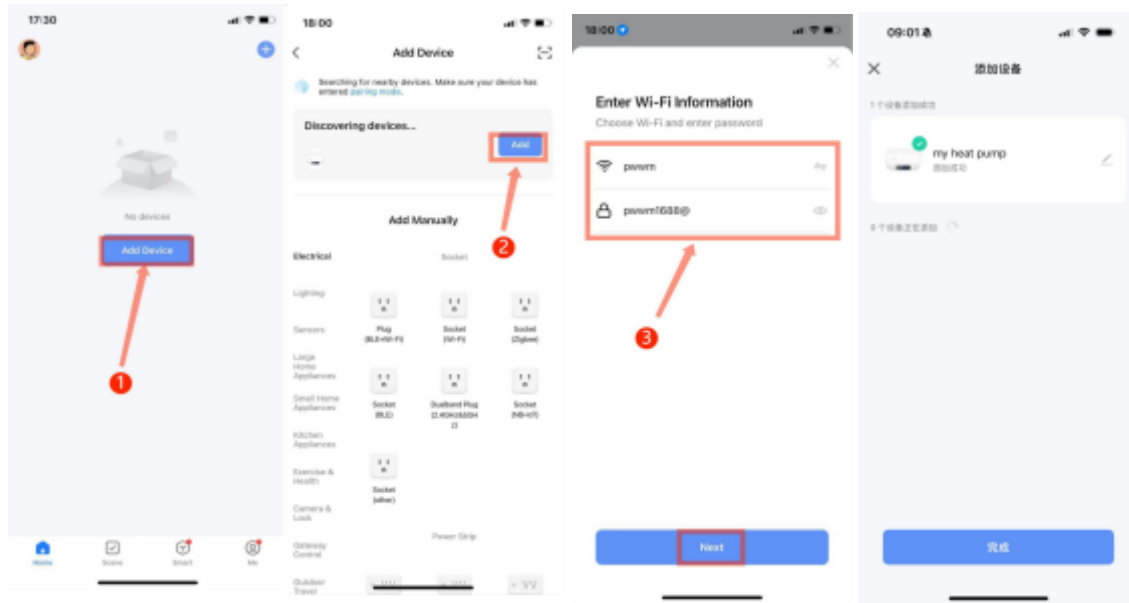

Add device solution 2:

Open the "Smart Life" APP, log in to the main interface, click "+" in the upper right corner, enter the device type selection, select " Large Appliances " → Select " Water Heater " →

Enter WiFi information → Complete ;

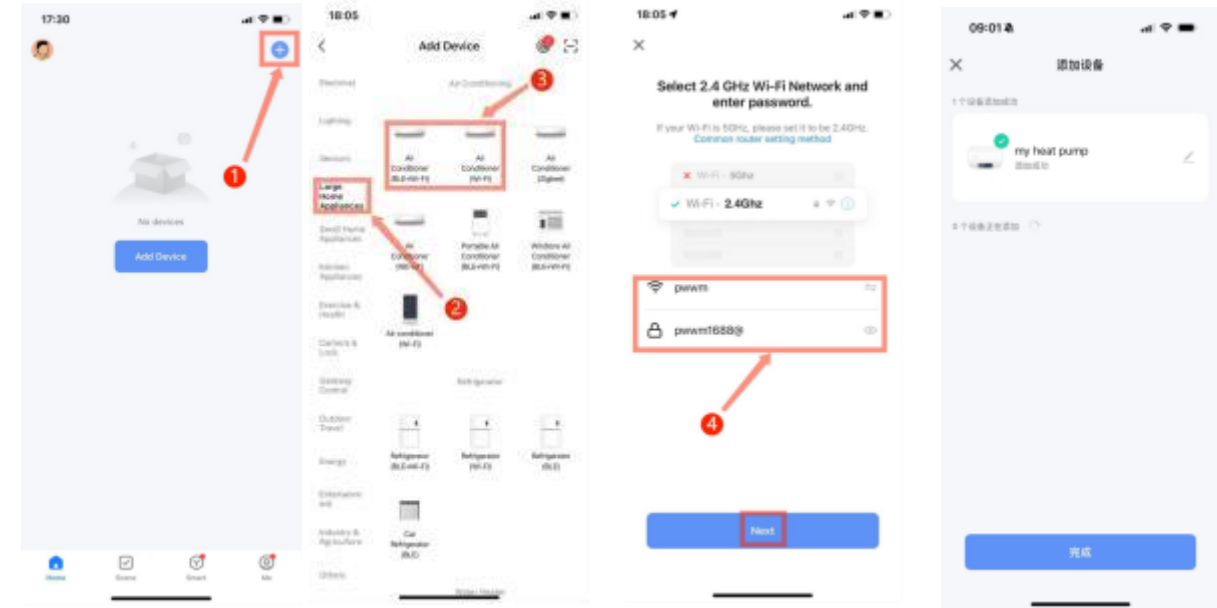

APP Introduction

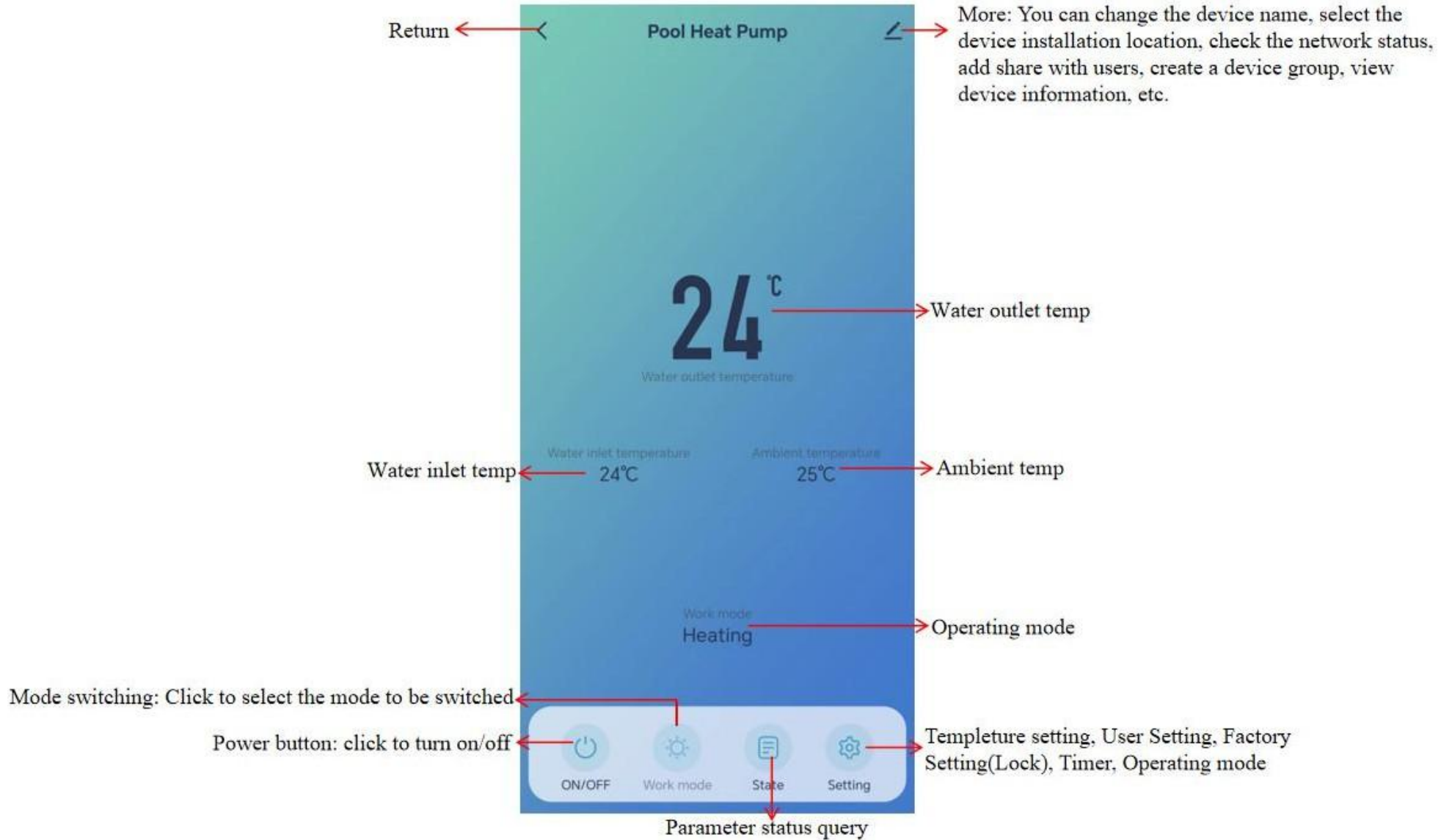

IoT Introduction

Real-time monitoring, data operation and maintenance, saving time and costs for users, dealers and manufacturers.

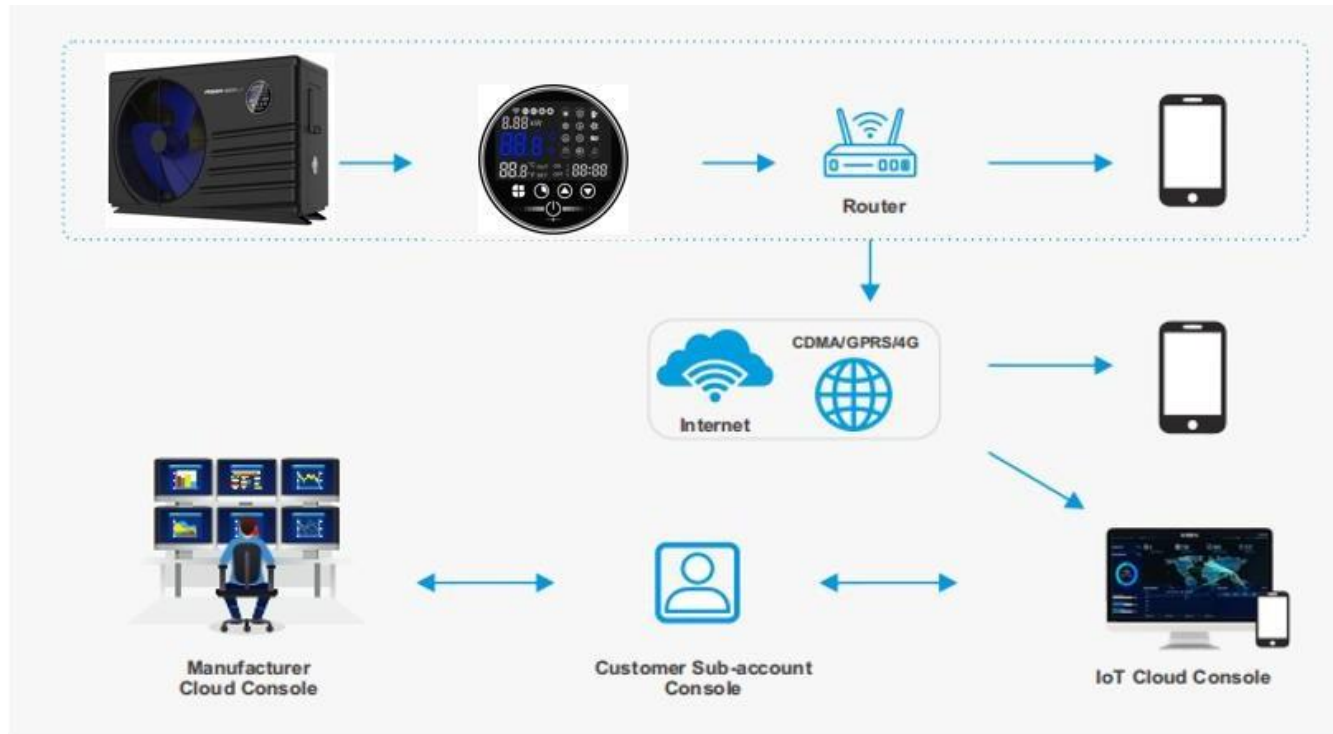

✓ **BIG DATA MANAGEMENT:**
Global device data collection, statistics, analysis and management.

✓ **EQUIPMENT MANAGEMENT**
Information statistics/operation status/parameter viewing and setting/fault diagnosis report/operation log, etc.

✓ **OTA UPGRADE**
Quickly fix code defects and remotely iteratively upgrade product motherboards.

R290 Refrigerant Leakage Detection



The heat pump is built in a refrigerant leakage sensor from factory, it's used to detect and monitor the leakage of R290 refrigerant, ensuring the safety and efficiency of the system. When the **leakage concentration exceeds 15% LFL**, the system will sound an alarm and display **fault code Er 75**, reminding users to handle it in a timely manner to ensure safe use.

The compressor and all electric heating will stop, and the fan is running at the lowest speed.

Solution:

Power off the unit immediately, keep good ventilate, check the refrigerant leakage point of the unit, and repair it. (Professional installation personnel are required to operate it)



Water Pump Connection

A second terminal block marked 'WATER PUMP' is located next to the first one. The filter pump (max. 5 A / 240 V) can be connected to the second terminal block here. This allows the filter pump operation to be controlled by the heat pump.

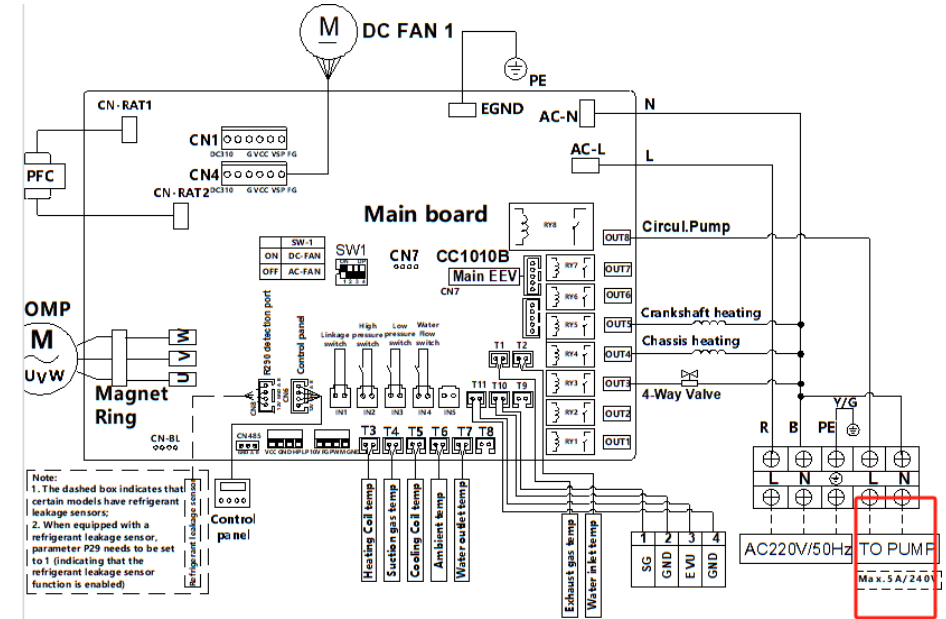
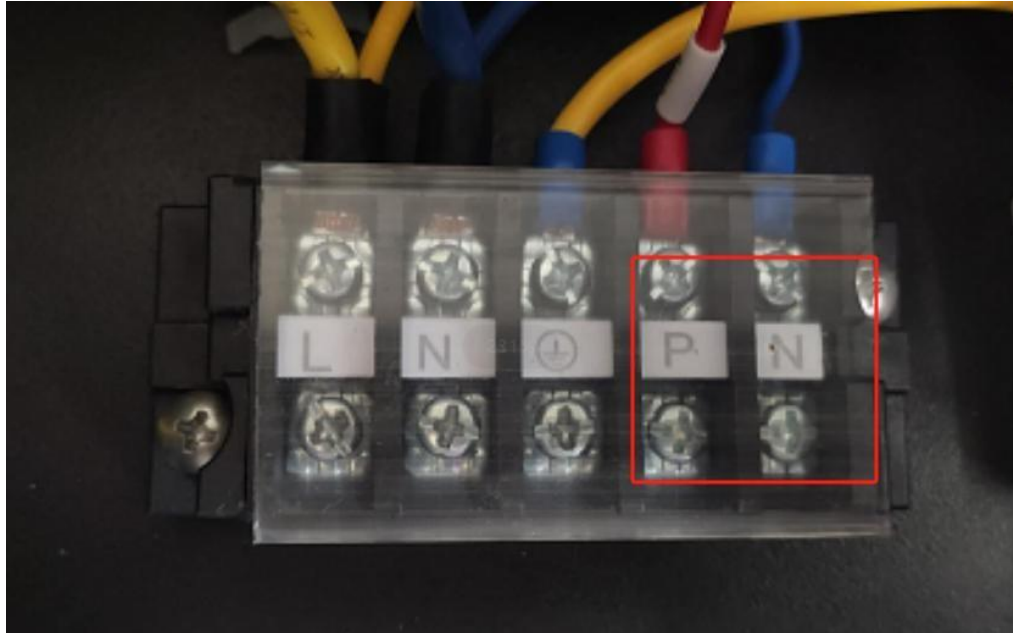

803004-3303 6P swimming pool electrical wiring diagram (R290)

Note:
1. The dashed box indicates that certain models have refrigerant leakage sensors.
2. When equipped with a refrigerant leakage sensor, parameter P29 needs to be set to 1 (indicating that the refrigerant leakage sensor function is enabled)



3

Curcuit Diagram

Curcuit Diagram



PW010/020/030/040/050 - KZXYC- E

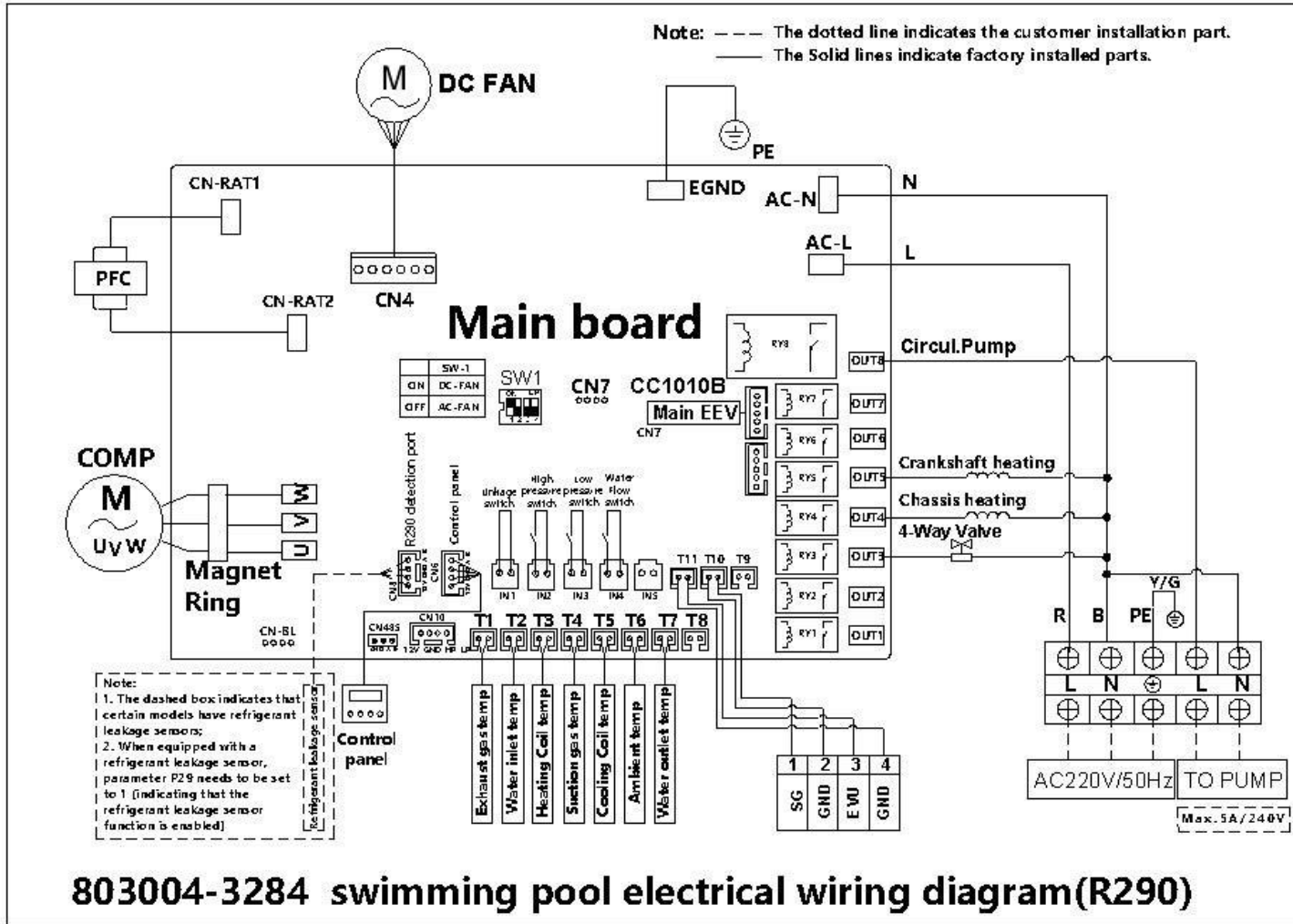

803004-3284 swimming pool electrical wiring diagram(R290)

Model	Fuse or circuit breaker (A)	Max. current (A)	Wire diameter mm ² (with max. 15 m length)
PW010	16	7.2	3*1.5mm ²
PW020	16	11.1	3*2.5mm ²
PW030	25	14.0	3*2.5mm ²
PW040	25	16.0	3*2.5mm ²
PW050	32	20.2	3*4 mm ²
PW060	32	25.2	3*4 mm ²
PW070	40	29.7	3*6 mm ²
PW080	40	31.8	3*6 mm ²

Curcuit Diagram

PW060 -KZXYC-E



Note: --- The dotted line indicates the customer installation part.
 — The Solid lines indicate factory installed parts.

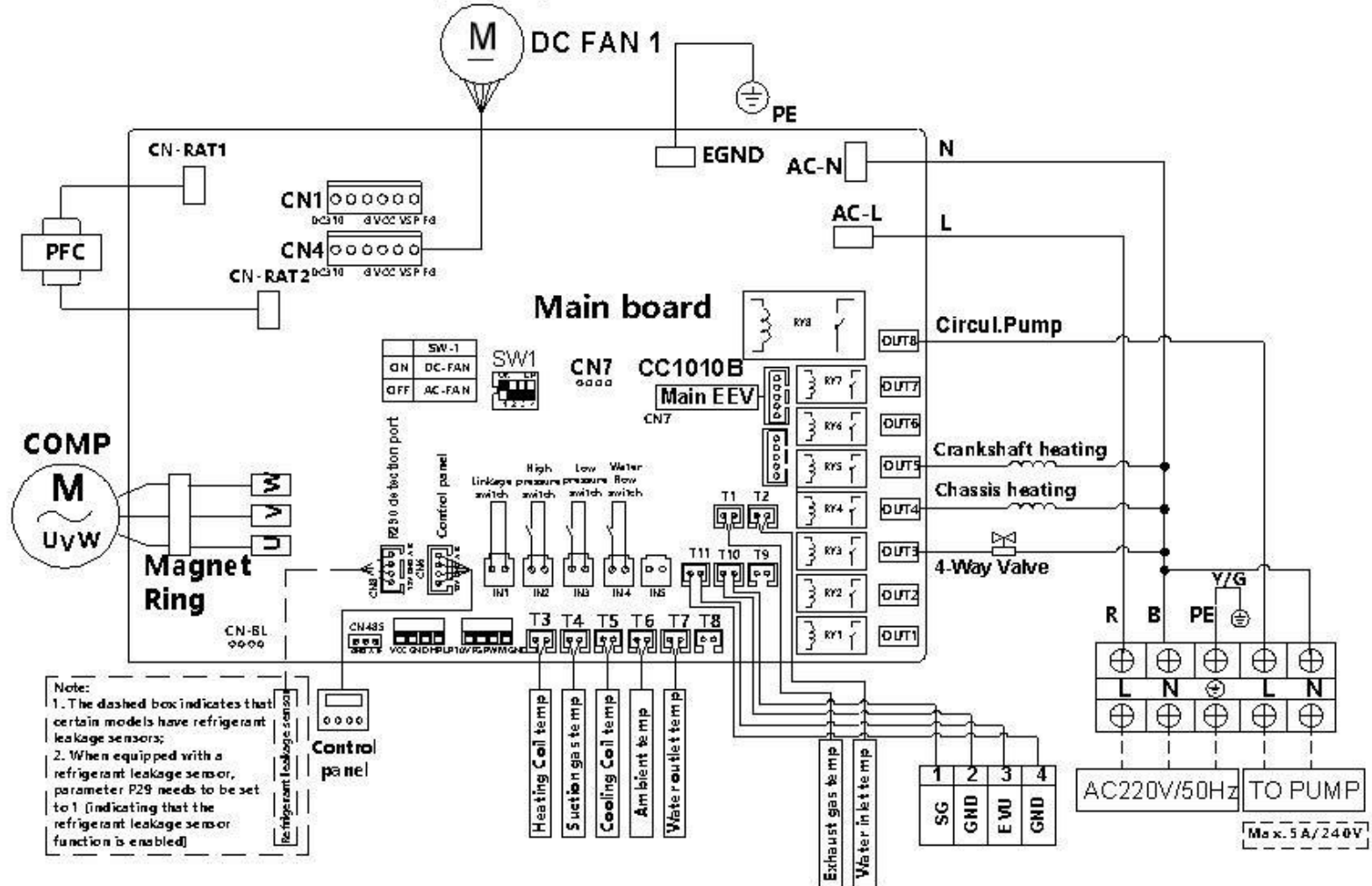

Note:
 1. The dashed box indicates that certain models have refrigerant leakage sensors;
 2. When equipped with a refrigerant leakage sensor, parameter P29 needs to be set to 1 (indicating that the refrigerant leakage sensor function is enabled)

803004-3303 6P swimming pool electrical wiring diagram (R290)

Curcuit Diagram

PW070/080 -KZXYC-E

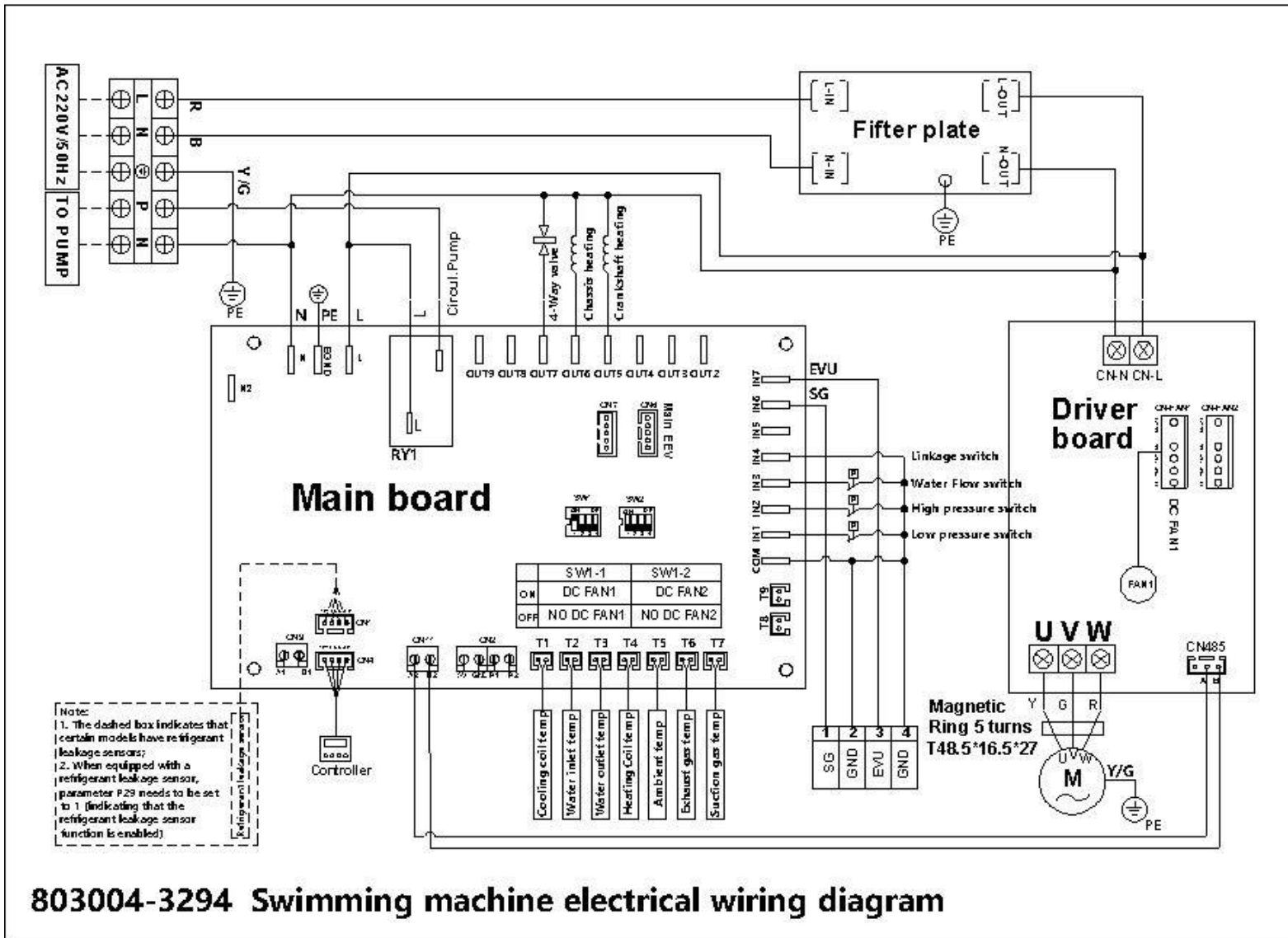

803004-3294 Swimming machine electrical wiring diagram

Thanks!